



Residential GenSet

- **Very Quiet Operation - 67 dB(A) at 7 m**
- **Aluminum weather resistant housing**
- **Fully Automatic Operation when used with an Onan Automatic Transfer Panel**
- **Available for use with Natural Gas or LP Vapor**
- **Attractive and Discreet Housing**
- **Electronic Governor for Precise Frequency Control**
- **Includes 120 V Coolant Heater**
- **Listed to UL 2200**

Models and Ratings

<u>Order Model</u>	<u>Fuel</u>	<u>Voltage</u>	<u>Rated kW</u>	<u>kVa</u>	<u>Rated Amps</u>	<u>Circuit Breaker</u>
30GGMC-6112	Nat. Gas	120/240	29	36	125	150-Amp, 2-Pole
30GGMC-6113	LP Vapor	120/240	30	38	125	150 Amp, 2-Pole

Weight, Size and Sound Level

- 1300 lb (590 kg)
- Footprint Dimensions (for recommended installation): Length: 64.4 in (635 mm); width: 30 in (762 mm); height: 46.7 in (1184.89 mm)
- Overall Dimensions: Length 85.3 in (2166.68 mm); width: 30 in (762 mm); height: 46.7 in (1184.89 mm)
- 67 dB(A) at 7 m, average

Site Derating Factors:

Natural Gas Engine power available up to 0 ft (0 m) at ambient temperatures up to 104° F (40° C). Above 0 ft (0 m) derate at 4% per 1000 ft (305 m), and 1.1% per 10° F (2% per 10° C) above 104° F (40° C).

Propane Engine power available up to 500 ft (153 m) at ambient temperatures up to 104° F (40° C). Above 500 ft (153 m) derate at 4% per 1000 ft (305 m), and 1.1% per 10° F (2% per 10° C) above 104° F (40° C).

Engine Facts

Engine: GM Industrial, spark-ignited
Design: In-line 4-cylinder, liquid-cooled
Compression Ratio: 10:5:1
Displacement: 181 cu in (3.0L)

Cooling System: 127° F (53° C) ambient cooling system
Oil Sump Capacity: 4.5 qt (4.3 L) with filter
Operating Speed: 1800 RPM

Engine Features

- Electronic ignition
 - Electronic governor
 - Full-pressure lubrication
 - High-capacity oil sump, spin-on oil filter
 - Solenoid shift starter
 - 150-amp, engine-driven battery charger
-

Exhaust Muffler

- Enclosed exhaust silencer
 - Low noise
-

Control System Features

- Automatic remote starting
 - Controls generator set starting and shutdown
 - Control components designed to withstand the vibration levels typical in generator sets
 - Field circuit breaker
 - High temperature, low oil pressure, overcrank and overspeed shutdowns
 - Running time meter
 - 150-amp UL-listed circuit breaker
 - DC control fuse
-

Generator Details

Design: Brushless, revolving field, single bearing, 4-pole, drip-proof construction

Insulation System: Class H per NEMA MG1-1.65 and BS2757

Temperature Rise: At rated load is less than 125° C at standby rating, per NEMA MG1.22.40, IEEE 115 and IEC 34-1

Exciter Type: The excitation system derives is a self (shant) excited system with the voltage directly from the generator set output.

Alternator Cooling: Direct drive centrifugal blower

Rotor: Supported by a pre-lubricated maintenance-free ball bearing

AC Wave form Total Harmonic Distortion: less than 5% total no load to full load

GenSet Performance

Voltage: 120/240 VAC, single phase, 1.0 pf

Voltage Regulation: ±1%, no load to full load

Frequency Regulation: Isochronous, 0% no load to full load

Random Frequency Variation: ±0.5% @ 60 Hz

Operating Temperature: -10° F (-23.3° C) or -20° F with optional coolant heater to 104° F (40° C)

Fuel Consumption-Natural Gas

Load:	1/4	1/2	3/4	Full
Cfh:	181.2	259.3	338.1	420
m ³ /hr:	5.1	7.3	9.6	11.9

Fuel Consumption-Propane

Load:	1/4	1/2	3/4	Full
Cfh:	64	91.7	119.6	148.3
m ³ /hr:	1.8	2.6	3.4	4.2

Basic Dimensions

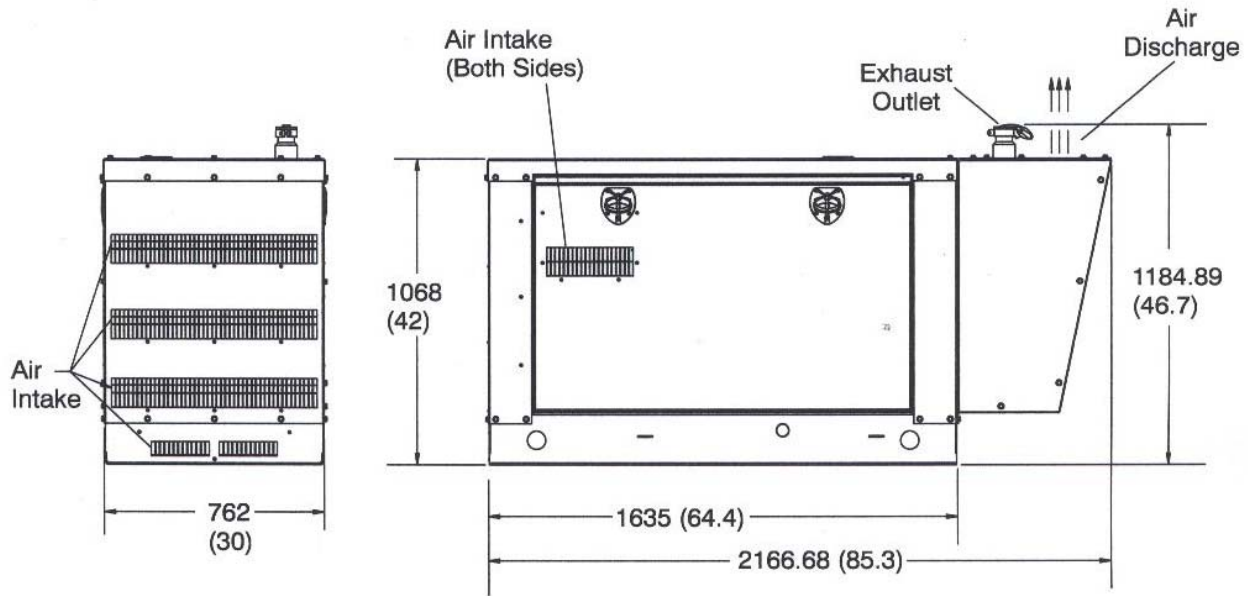

mm(in)

Drawing Reference Number 0500-4511 or 0500-4512

Automatic Transfer Panel Configurations

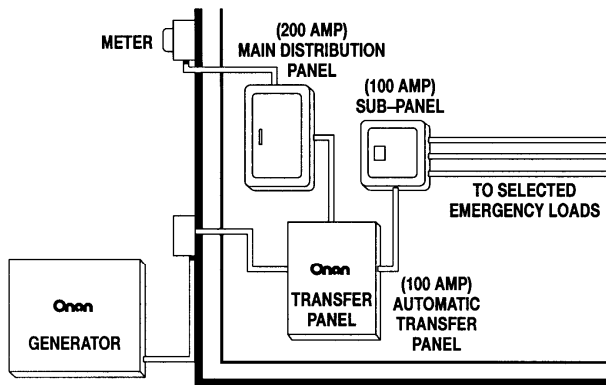

Dedicated Emergency Standby Service System (100 Amp)

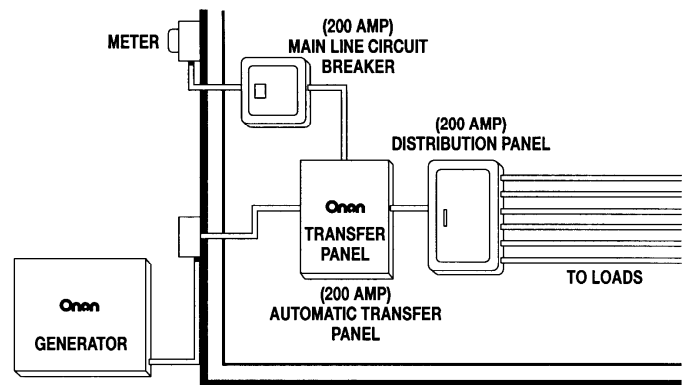

Full-Service Rating Standby System (200 Amp)

Housing Features

- Weather protective design, two easy service access doors -- key-lockable
- Internal starting battery tray and tie down
- Heavy-duty aluminum housing

Options and Accessories

- Battery, 12 V, 325 cca (Part #416-0774)
- Battery heater kit (Part #333-0469)
- Full line of complementing automatic transfer panels

Warranty Policy

The Onan RS 30000 Home Standby System comes with a standard one-year warranty. Additional two and five-year warranty options are available. See your certified distributor or dealer for details.

After Sale Support

GENUINE ONAN MAINTENANCE CARE PARTS AND PRODUCTS - For your ongoing satisfaction and the dependability of your Onan genset, Onan offers a complete line of parts, oil and maintenance chemicals specifically designed for Onan gensets and available at your nearby Onan dealer.

EASY TO LOCATE CERTIFIED ONAN SERVICE AND PARTS DEALERS - Onan has trained, tested and certified over 1000 authorized Onan Service Dealers covering most major metropolitan areas in the U.S. and Canada. To easily locate the certified Onan Service Dealer no matter where you travel, call 1-800-888-ONAN or look in the yellow pages under "generators, electric".

See your distributor for more information



877-456-2424 | fax 828-743-2140 | office 828-743-4242
448 Hwy 64 West, Suite 5 | Cashiers, North Carolina 28717
www.aspowersystems.com



Cummins Power Generation



CSA-certified for electrical equipment. Meets CSA C22.2



Onan is a registered trademark of Cummins Inc.

Important: Backfeed to a utility system can cause electrocution and/or property damage. Do not connect to any building's electrical system except through an approved device or after building main switch is open. Standby Rating based on: Applicable for supplying emergency power for the duration of normal power interruption. No sustained overload capability is available for this rating. (Equivalent to Fuel Stop Power in accordance with ISO3046, AS2789, DIN6271, and BS5514.) Nominally rated. (See T-030 document for more information.)